

## Eliminates most of the dismantling needed to do a simple metal cutting repair job.

The rugged and dependable Climax Model PL3000 Portable Lathe is a precision machine tool engineered re-turn large shafts and roll journals by bolting directly to the end of the workpiece and rotating around the shaft.

### Heavy duty, powerful, precise

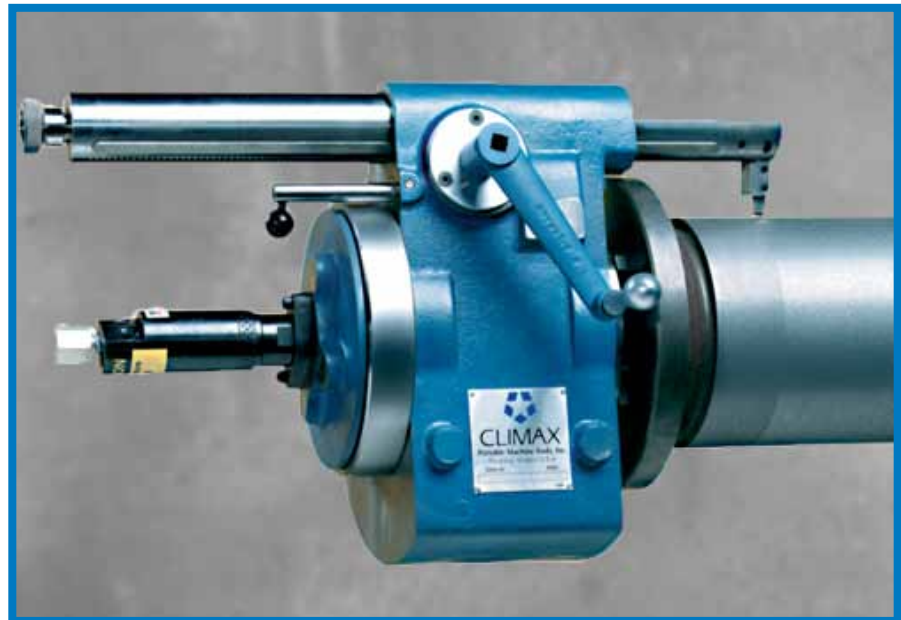





- Heavy solid steel turning bar and counterbalanced body provide smooth turning and minimum chatter, even with the turning bar at maximum reach.
- The motor and planetary ring gear drive provide enough torque to remove up to 0.125 inch (3.175 mm) of metal so you can get the job done fast.
- A 3.08 Hp (2.3 kW) electric motor and a 1.22 Hp (0.91 kW) pneumatic motor is available.
- Tool reach is 16.0 inches (406.4 mm) from end of shaft, and up to 22.0 inches (558.8 mm) with optional turning bar extension.
- Turns shafts from 4.0 - 11.25 inches (101.6 - 285.75 mm). (This machine works within a 16.75 inch (425.5mm) diameter space around the shaft (swing diameter), and 36 inches (914.4 mm) from the end of the shaft.)
- Automatic axial feed is variable from 0.003 - 0.011 inches/rev. (0.076 - 0.279 mm/rev.) in 7 increments

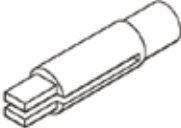

### Quick and easy to set up

- Mounts on the end of the shaft. Simply remove the gear or bearing to expose the end of the shaft.
- The PL3000 can be set up by an experienced operator in less than an hour. Drill and tap four mounting holes on the end of the shaft to attach the tapered mounting flange.
- Adjusting screws allow accurate centering and alignment even if the shaft face is no longer square.

# ACCESSORIES

No.	Description	No.	Description														
	<p><b>10649</b> <a href="#">PL3000 portable lathe, pneumatic</a> <a href="#">10649CE CE-Compliant model</a></p> <p>Complete lathe machine. Turns shafts and roll journals 8.0 - 11.0 inches (203.2 to 279.4 mm) in diameter. Machine mounts to the end of the shaft with a blank tapered mounting flange (included). Also includes counterbalanced mainbody, pneumatic planetary housing, 1.22 hp (.91 kW) air motor, pneumatic conditioning unit, 16.0 inch (406.4 mm) reach turning bar, abrasive belt holder, tool kit with 3/8 inch (or 10 mm) square HSS lathe tool and dial indicator, instruction manual, and wooden storage crate.</p>		<p><b>10586</b> <a href="#">Abrasive belt holder</a></p> <p>Belt holder mounts to the tool end of the turning bar. Use with an abrasive belt to produce a fine finish on the shaft. Abrasive belts not provided.</p>														
	<p><a href="#">Model PL3000 portable lathe, electric</a></p> <p>As above with electric motor and speed control instead of the air motor and pneumatic conditioning unit.</p> <p><b>13872</b> PL3000 Portable lathe, 120V motor <b>15524</b> PL3000 Portable lathe, 230V motor</p>		<p><b>11784</b> <a href="#">ID Mounting collet assembly</a></p> <p>Allows the PL3000 to be mounted inside work piece diameters from 4.7 - 10.95 inches (119.4 - 278.1 mm). Assembly includes ID mounting flange, collet body with fingers and jaws, screw shaft with threaded cones, and necessary hardware.</p> <p><b>28545</b> ID mounting collet assembly, no jaws Same as above without fingers or jaws.</p> <p><a href="#">ID jaw sets</a></p> <table border="1"> <thead> <tr> <th>Jaw set</th> <th>Fits in dia.</th> </tr> </thead> <tbody> <tr> <td><b>28539</b> 0.5 (12.7)</td> <td>4.7 - 5.95 (119.4 - 151.1)</td> </tr> <tr> <td><b>28540</b> 1.0 (25.4)</td> <td>5.7 - 6.95 (144.8 - 176.5)</td> </tr> <tr> <td><b>28541</b> 1.5 (38.1)</td> <td>6.7 - 7.95 (170.2 - 201.9)</td> </tr> <tr> <td><b>28542</b> 2.0 (50.8)</td> <td>7.7 - 8.95 (195.6 - 227.3)</td> </tr> <tr> <td><b>28543</b> 2.5 (63.5)</td> <td>8.7 - 9.95 (221.0 - 252.7)</td> </tr> <tr> <td><b>28544</b> 3.0 (76.2)</td> <td>9.7 - 10.95 (246.4 - 278.1)</td> </tr> </tbody> </table>	Jaw set	Fits in dia.	<b>28539</b> 0.5 (12.7)	4.7 - 5.95 (119.4 - 151.1)	<b>28540</b> 1.0 (25.4)	5.7 - 6.95 (144.8 - 176.5)	<b>28541</b> 1.5 (38.1)	6.7 - 7.95 (170.2 - 201.9)	<b>28542</b> 2.0 (50.8)	7.7 - 8.95 (195.6 - 227.3)	<b>28543</b> 2.5 (63.5)	8.7 - 9.95 (221.0 - 252.7)	<b>28544</b> 3.0 (76.2)	9.7 - 10.95 (246.4 - 278.1)
Jaw set	Fits in dia.																
<b>28539</b> 0.5 (12.7)	4.7 - 5.95 (119.4 - 151.1)																
<b>28540</b> 1.0 (25.4)	5.7 - 6.95 (144.8 - 176.5)																
<b>28541</b> 1.5 (38.1)	6.7 - 7.95 (170.2 - 201.9)																
<b>28542</b> 2.0 (50.8)	7.7 - 8.95 (195.6 - 227.3)																
<b>28543</b> 2.5 (63.5)	8.7 - 9.95 (221.0 - 252.7)																
<b>28544</b> 3.0 (76.2)	9.7 - 10.95 (246.4 - 278.1)																
	<p><a href="#">Tapered mounting flange assembly</a></p> <p>Precision machined mounting flange securely mounts the portable lathe to the end of the shaft. One blank mounting flange is included with the machine.</p> <p><b>10640</b> Blank tapered mounting flange assembly. Machine to your mounting configuration. <b>10642</b> Machine tapered mounting flange assembly. Factory machined to your mounting specifications.</p>																
	<p><b>10636</b> <a href="#">Turning bar extension - 22 inch (558.8 mm) reach</a></p> <p>Mount the turning bar extension between the end of the standard turning bar and the tool housing to extend the reach of the bar from 16.0 - 22.0 inches (406.4 - 558.8 mm). For longer bar reaches, contact your Climax representative.</p>																
	<p><b>37811</b> <a href="#">Tooling Pack (not shown)</a></p> <p>One HSS 3/8 inch x 3.0 inch side cutting tool bit, and one HSS 3/8 inch x 3.0 inch top cutting tool bit in storage case.</p>																
	<p><a href="#">Tool holders</a></p> <p>Extra tool holders for use with the standard 16.0 inch (406.4 mm) turning bar and the 22.0 inch (558.8 mm) turning bar extension. Holders use 3/8 inch or 10 mm square HSS lathe tool bits.</p> <p><b>10643</b> Tool holder, 4 - 6 inches Used to turn shafts 4 - 6 inches (101.6 to 152.4 mm) in diameter <b>10644</b> Tool holder, 6 - 8 inches Used to turn shafts 6 - 8 inches (152.4 to 203.2 mm) in diameter. <b>18368</b> Tool holder, 8 - 11 inches Used to turn shafts 8 - 11 inches (203.2 to 279.4 mm) in diameter</p>																
			<p>NOTE: Drawings are for reference only, are not to scale, and may not represent actual product.</p>														



# SPECIFICATIONS

	US	Metric
Overall length, electric		
std. bar fully retracted	27.0 inches	685.8 mm
std. bar fully extended	43.0 inches	1092.2 mm
Overall length, pneumatic		
std. bar fully retracted	31.0 inches	787.4 mm
std. bar fully extended	47.0 inches	1193.8 mm
Overall width	10.5 inches	266.7 mm
Overall height, with the optional	16.0 inches	406.4 mm
Turning Reach (from spindle face)		
standard bar	16.0 inches	406.4 mm
standard bar w/ optional extension	22.0 inches	558.8 mm
Shaft dia. max	11.25 inches	285.8 mm
Shaft dia. min		
with standard tool holder (18368)	8.0 inches	203.2 mm
with optional tool holder (10644)	6.0 inches	152.4 mm
with optional tool holder (10643)	4.0 inches	101.6 mm
Swing clearance, min. radius	8.375 inches	212.7 mm
Axial feed, automatic	0.003 - 0.011 inches/rev	0.076 - 0.279 mm/rev
Turning bar diameter	2.31 inches	58.7 mm
Cutter	3/8 inch lathe tool bit	10 mm lathe tool bit
Tool depth adjustment, manual	1.125 inches total	28.575 mm total
radial travel in three increments of:	0.375 inches	9.525 mm
Power, electric		
120V, 60 Hz continuous	3.08 Hp	2.30 kW
Intermittent	4.80 Hp	3.58 kW
230V, 50 Hz continuous	3.08 Hp	2.30 kW
Intermittent	4.80 Hp	3.58 kW
Torque: 98 ft-lbs (135 N-m) max at 72 rpm bar speed. Bar free speed: 72 rpm max. Gear ratio: 8:1. Variable speed control with settings 20 - 72 rpm.		
Power, pneumatic 1.22 Hp 0.91 kW		
[non-reversing, Hp rated at 265 rpm). Torque: 24.2 ft-lbs (32.9 N-m) at full power, 33 rpm. Gear ratio 8:1. Infinitely variable speed control with needle valve. Air flow required: 90 psi @ 30 ft <sup>3</sup> /min (620 kPa @ 0.85 m <sup>3</sup> /min).]		
Operating weight	200 lbs.	90.7 kg
Shipping weight	261 lbs.	118.4 kg
Shipping dimensions L x W x H	33 x 27 x 17 inches	838.2x685.8x431.8 mm

All dimensions should be considered reference. Contact your Climax Representative for precision dimensions. Specifications are subject to change without notice. There are no systems or components on this machine that are capable of producing hazardous EMC, UV or other radiation hazards. The machine does not use lasers nor does it create hazardous materials such as gasses or dust.

# OPERATIONAL DIMENSIONS

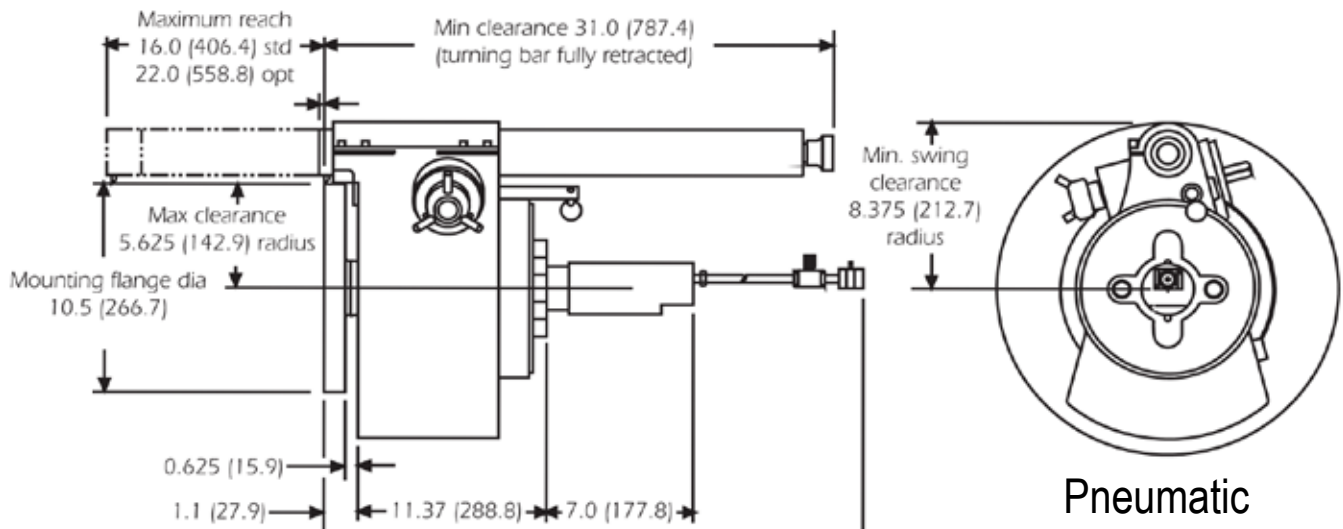
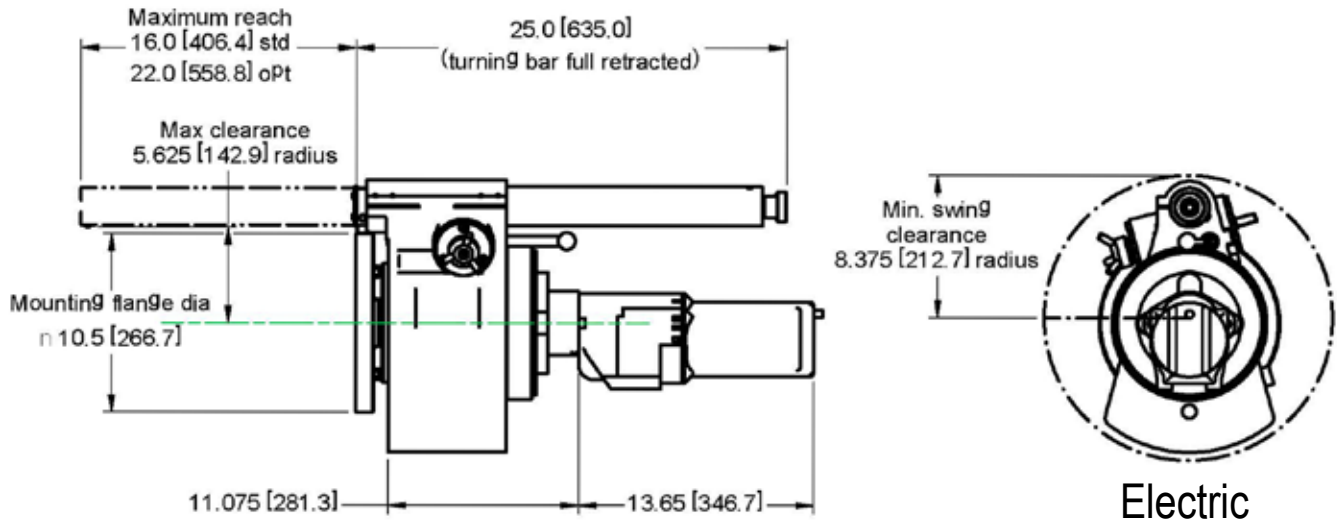

# Training at the Global Learning Center

Climax has been teaching the fundamentals and fine points of portable machine tool operation for practically as long as we've been inventing and building the tools.

At the Climax Global Learning Center situated in our corporate headquarters near Portland, Oregon, we provide training for machine tool operators on portable machine tool safety, and machine setup and operation. Trainees also receive technical tips and tools to improve operational efficiencies, with the vast majority of every program devoted to hands-on activities and skill development.



The Climax instructional team includes specialists in shipbuilding, power generation, civil engineering, bridge re-building, petrochemical and other industries.

Whether it's a regularly scheduled course at the Global Learning Center, or custom curriculum conducted at your facility, your machinists will benefit from courses developed by some of the most respected authorities in the business.

Call us today to register for a regularly scheduled class, or talk to us about how we can customize a training program for your specialized application.



# CLIMAX GLOBAL LOCATIONS



## Call Climax for:

### On-site Training

Need some refresher courses in setting up and operating your Climax machine tool?

### Special Projects

Climax has been solving complicated on-site machining and welding problems for our customers since 1964.

### Rentals

With seven locations in North America, two in Europe and two in Asia, you are never far away from a Climax portable machine tool.

Connect with us:  

### World Headquarters

2712 E. Second Street  
Newberg, Oregon 97132 USA  
Worldwide Telephone: 1.503.538.2185  
N. America Toll-Free: 1.800.333.8311  
Fax: 1.503.538.7600  
Email: [info@cpmt.com](mailto:info@cpmt.com)

### European Headquarters

Am Langen Graben 8  
52353 Düren, Germany  
Telephone: (+49) (0) 2421.9177.0  
Fax: (+49) (0) 2421.9177.29  
Email: [info@cpmt.de](mailto:info@cpmt.de)

Copyright © 2012 Climax Portable Machining & Welding Systems. All Rights Reserved. Climax has taken reasonable measures to ensure the accuracy of the information contained in this document. However, Climax makes no warranties or representations with respect to the information contained herein; and Climax shall not be held liable for damages resulting from any errors or omissions herein, or from the use of the information contained in this document.

 **CLIMAX**  
Portable Machining & Welding Systems