

# TYPE 4 TUBE PULLER

Tubes up to 1 inch  
AUTOMATIC / CONTINUOUS

Jaw system grips tube full length  
Pulls one or both expansion joints  
Low pressure-HI flow hydraulic system

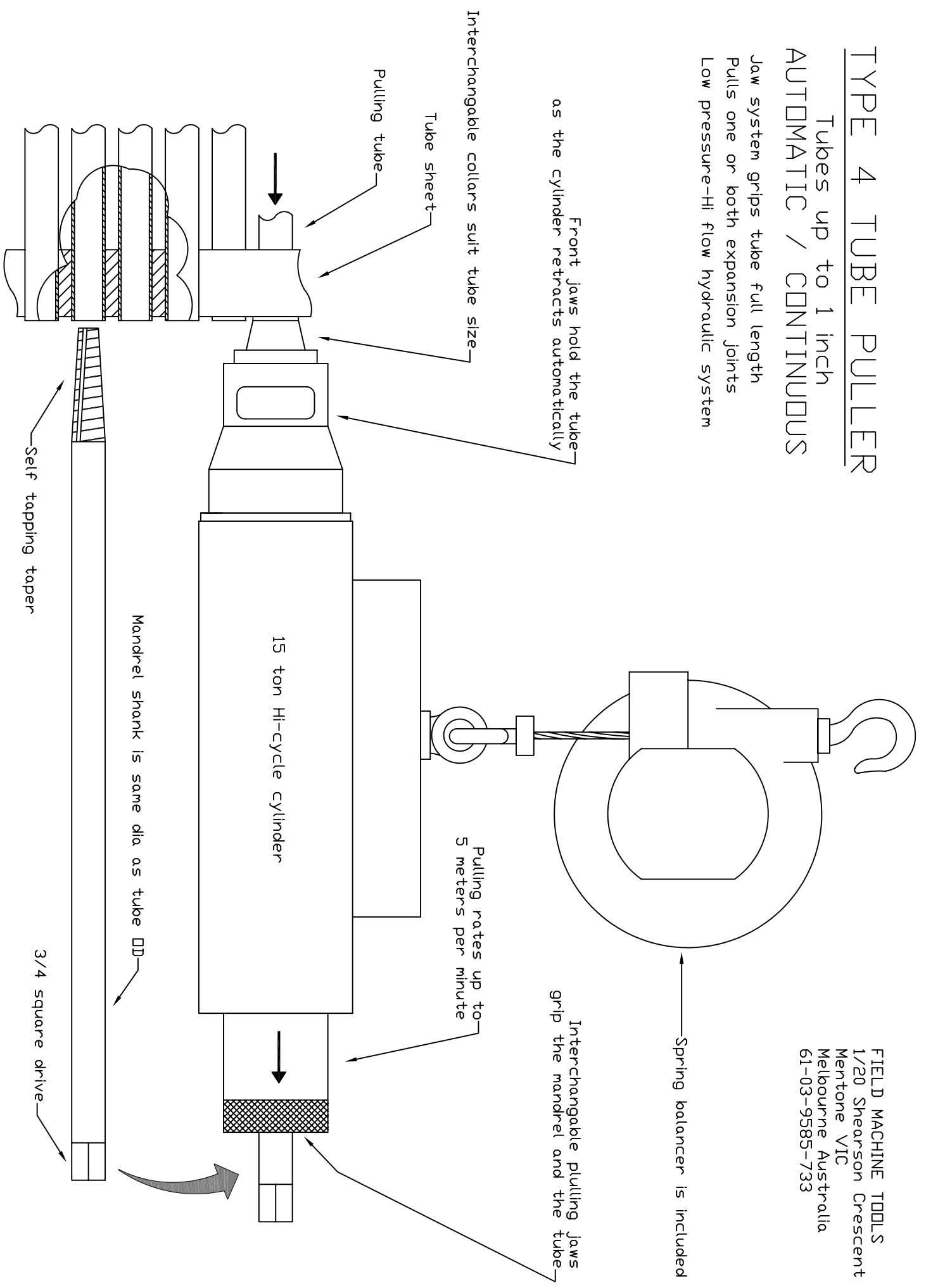

FIELD MACHINE TOOLS  
1/20 Shearson Crescent  
Mentone VIC  
Melbourne Australia  
61-03-9585-733