

Designed to get the job done *FAST!*

Lightweight

- Body of machine weighs only 27 kg (60 lbs).
- Smallest mounting chuck weighs about 2.2 kg (5 lbs).

Quick & Easy Setup

- Separate mounting chuck.
- All centering & leveling done right on chuck.

Low Profile

- Right angle motor mount.
- Machine extends only 193mm (7.6") above flange.

Simplified Operation

- Single selector for bidirectional radial or downfeed.
- One wrench for clamping jaws and body draw bolt.

Quiet

- Exhaust air is routed through body of machine for muffling.

Safe Operation

- Stationary feed rate selector.
- Machine is controlled without touching any moving parts.

Easy Mounting/Dismounting

- Loosen one bolt and machine can be removed from chuck without disturbing alignment.

Cuts Chamfers & Groves

- Compound tool head & downfeed for cutting angles and groves.

Overhead View

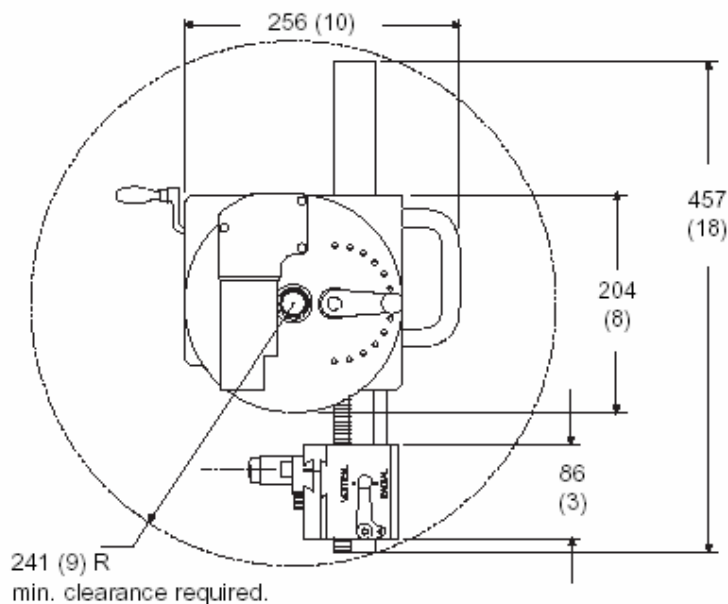

Side View

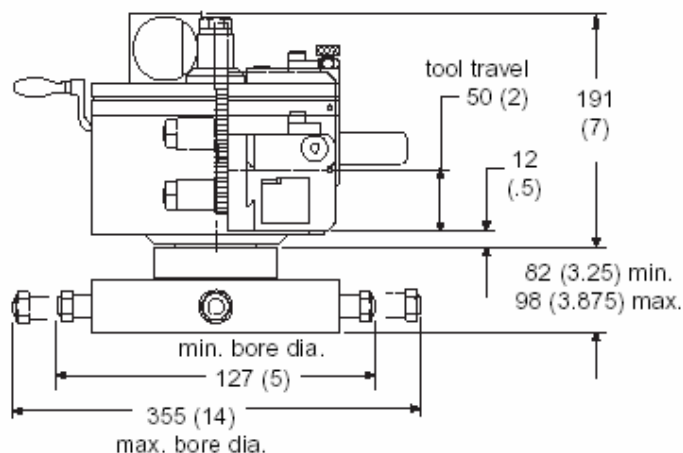

Measurements are: mm (inch)

Setup of the Model FF5000 is quick and easy.

Experience operators can have this machine mounted, aligned, and ready to cut in about 15 minutes (depending on site conditions). Lightweight, alignable mounting chucks eliminate many problems associated with other portable flange facers.

1 With the proper set of jaws inserted, place the mounting chuck into the flange bore resting on the setup bars. Snug the jaws up to hold the chuck in place.

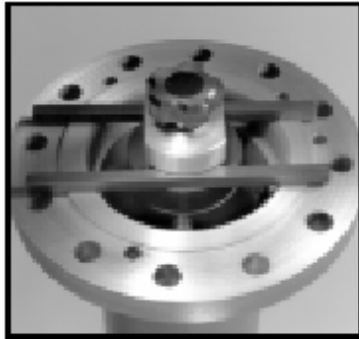

3 Attach the machine body with one draw bolt. The machine may be removed and replaced if necessary, without disturbing the alignment.



2 Use the special indicator accessory to center the chuck in the bore, then tighten the jaws securely. Align the chuck for flatness across the flange by adjusting the leveling screws.



4 Position the tool head with the hand crank so the cutter is at the desired starting point. The Model FF5000 Flange Facer is ready to run.



MELBOURNE
SYDNEY
BRISBANE
PERTH
ADELAIDE
SINGAPORE

FMT
WINEMA
TRU-BLU TORQUE
TRU-BLU TORQUE
AIRQUIP & PIPETOOL
HYTEC GROUP

03-9585-7333
02-9530-5484
07-3267-6844
08-9455-7522
08-8398-5111
65-6898-5055