



Field Machine Tools Pty Ltd

ABN 48 097 691 748

1/26 Shearson Crescent

Mentone VIC 3194

www.fmt.com.au

sales@fmt.com.au

Ph: 1300 FMT FMT Fx: 03 9585 7355

International

Ph: 617 3267 6844 Fx: 617 3267 8244

**H&S
TOOL, INC.**



Clamshells

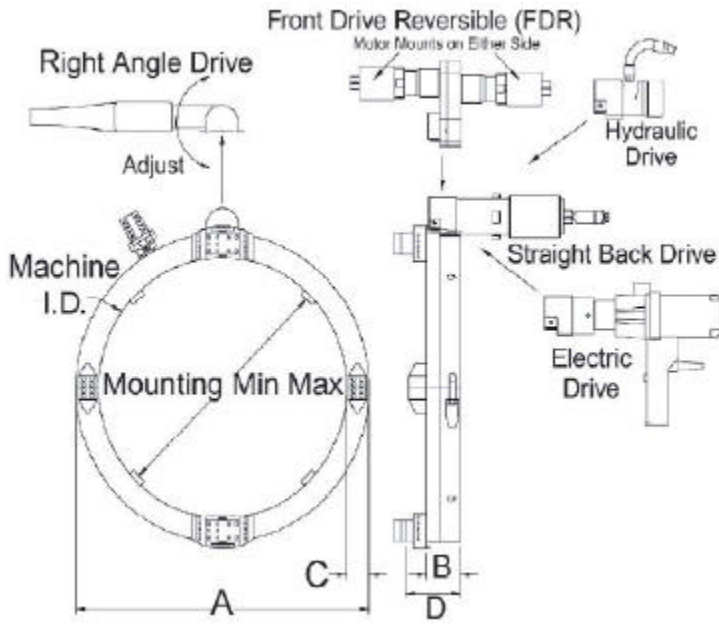

Description

DLR's Clamshell lathes are portable pipe cutting machines designed for accurate on-site severing, bevelling, ID boring, facing and O.D turning. These clamshells are available in a wide range of sizes and the split ring assembly provides them with the capability of being mounted around in-line piping. DLR's cutting tool bits are available for severing, severing and double bevelling, severing and bevelling on the side of the cut on which the clamshell is mounted (right hand), severing and bevelling on the opposite side of the cut (left hand), counter boring, socket weld removal, etc. Clamshells can be used in any environment making them perfect for underwater, petrochemical or other hazardous conditions.

Model	Size Inches	Size mm	A	B	C	D
MC-2	0.84-2.37	21.3-60.3	163 mm	82 mm	48 mm	109 mm
NB-4	1.90-4.50	48.3-114.0	235 mm	76 mm	57 mm	114 mm
NB-6	2.38-6.23	60.3-168.3	289 mm	76 mm	57 mm	114 mm
NB-8	3.50-8.63	88.9-219.1	338 mm	76 mm	57 mm	114 mm
NB-10	4.50-10.75	114.3-273.1	400 mm	76 mm	57 mm	114 mm
NB-12	6.23-12.75	168.3-323.9	451 mm	76 mm	57 mm	114 mm
NB-16	10.62- 16.00	219.1-406.0	533 mm	76 mm	57 mm	114 mm
NB-20	14.00- 20.00	355.6-508.0	635 mm	76 mm	57 mm	114 mm
MS-20	11.37-20.25	187.0-413.1	877 mm	77 mm	97 mm	135 mm
NB-24	18.00-24.00	457.2-609.6	737 mm	76 mm	57 mm	114 mm
NB-26	20.00-26.00	508.0-660.4	787 mm	76 mm	57 mm	114 mm
NB-30	24.00-30.00	609.6-762.0	889 mm	76 mm	57 mm	114 mm
NB-36	30.00-36.00	762.0-914.4	1041 mm	76 mm	57 mm	114 mm
NB-43	37.00-43.00	939.8-1092.2	1219 mm	76 mm	57 mm	114 mm
HD-50	88-00-50.00	965.2-1270.0	1533 mm	159 mm	122 mm	216 mm
HD-60	48.00-90.00	1219-1524-0	1793 mm	159mm	122 mm	216 mm

MELBOURNE BRISBANE PERTH NEWCASTLE ADELAIDE DARWIN